

气动接头综合样本

4.0版



## 欢迎来到赛德斯的产品世界

欢迎来到赛德斯的产品世界！

这本“气动接头综合样本”将带您浏览赛德斯的全部产品。希望它的易读和实用能成为您手边得力的工具手册。如果您想获得更多的信息，请联系我们或登录我们的网站，您将会发现更多关于赛德斯的产品信息。



浙江省乐清市北白象镇白塔王工业区东盛东路119  
电话：0577-62693377  
传真：0577-62676052  
邮箱：sds@sdsqd.com  
www.sdsqd.com

**SADES**<sup>®</sup>  
赛德斯气动

## 创意产生技术

---

创意会产生不同凡响的产品、新的设计理念和革新的加工方法。

赛德斯的茁壮成长来自员工的不断创新。公司重视将每个员工从简单的、重复性劳动中解脱出来，并将这部分工作交付给符合环保安全规范的全自动设备去完成，从而使员工能将自己的创造力发挥到极限。

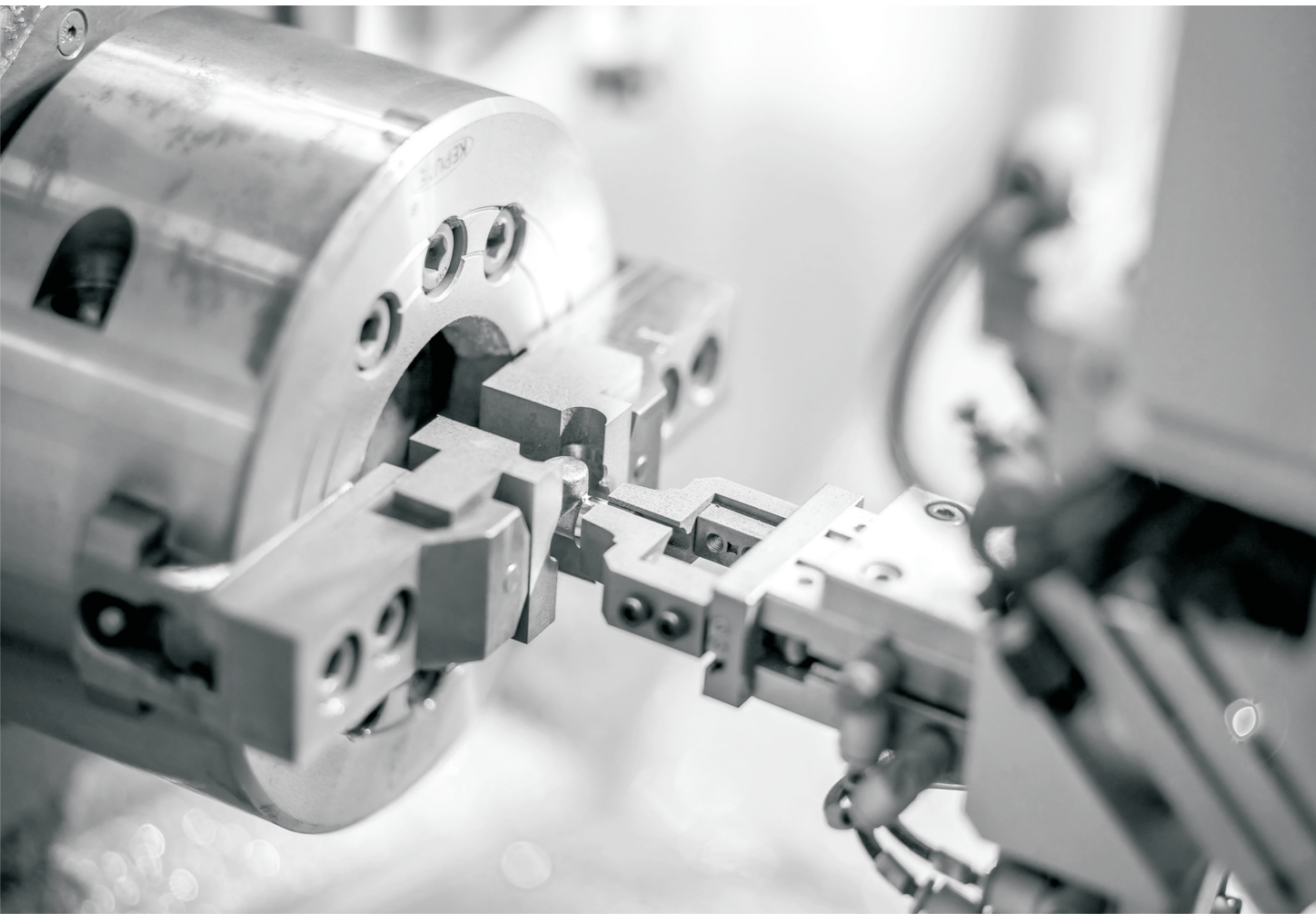

## 我们的承诺，是我们成功的秘诀

管理团队的架构是赛德斯持续成长和发展的中心，它由复杂的信息管理系统作为支持，实现赛德斯业务的垂直集成。

赛德斯设计，生产和检测的每一个元件都力求精益求精，以可能达到的最高性能指标为准则。

客户复杂多变的需求不仅要求我们不断推出新的产品，而且需要不断提高产品质量，完善售后服务。赛德斯遍及全球的销售网络使我们能迅速地满足全球任何一个地方的需求。

在追求完美和高效的路上，赛德斯将始终怀着乐观，忠诚和激情去满足瞬息万变的市场需求和来自各方的挑战。



## 目录

1> TKC系列	铜快插管接头
	1-P01~P19
2> TSS系列	双密封铜快插管接头
	2-P20~P21
3> TKN系列	铜快拧管接头
	3-P22~P34
4> TKT系列	铜卡套管接头
	4-P35~P40
5> 阀系列	阀类铜接头
	5-P41~P53
6> 欧式快速系列	欧式迷你自锁铜接头
	6-P54~P58
7> 消声器系列	消声器
	7-P59~P61
8> 管道系列	铜管道接头
	8-P62~P68

# TKC系列全铜快插管接头

连接管外径 3, 4, 6, 8, 10, 12, 14, 16mm

连接螺纹 R1/8, R1/4, R3/8, R1/2, G1/8, G1/4, G3/8, G1/2  
M5, M6, M8, M10



**TKC系列快插管接头** 共有35种不同的类型，可以在不借助工具的情况下方便地插入或拔出气管，且可重复使用。管接头内的O型圈损坏或随着时间的变化而损耗时，可以方便的更换。

管接头由黄铜制成，表面镀镍。

## 综合参数

材料	镀镍黄铜基体及槽夹头，丁腈橡胶O型圈
连接螺纹	英制锥管螺纹ISO7(BSPT) 英制圆柱管螺纹 ISO 228(BSP) 公制M5-M6-M8-M10
工作压力	0.095~2.5MPa (使用时，同时取决于连接管的耐压)
连接管材料	PU (聚氨酯)、尼龙 (PA6-PA11-PA12)、聚乙烯 (PE)
连接管外径	3~16mm
介质	压缩空气 (如果用于其它介质，请联系我们的销售工程师)
工作温度	-30~120°C (使用时，同时取决于连接管的工作温度)

\*可按要求提供其他材质的O型圈和密封件  
\*\*可按要求提供NPT螺纹制式的管接头

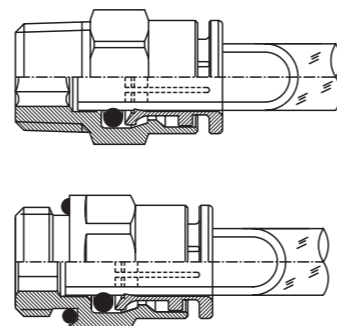

## TKC-PC...型全快插管接头



尺寸表

型号	A	D	C	F	L	G	H	SW	SW1	重量 (g)
TKC-PC4-01	4	R1/8	13.5	8	17	11.3	8	10	2.5	5.6
TKC-PC4-02	4	R1/4	13.5	8	18	15.8	9	14	-	13.8
TKC-PC6-01	6	R1/8	17	11.8	23.4	13.5	8	12	4	10.1
TKC-PC6-02	6	R1/4	17	11.8	21.2	15.8	9	14	4	13.7
TKC-PC6-03	6	R3/8	17	11.8	19.2	19.1	9.5	17	4	23.4
TKC-PC6-04	6	R1/2	17	11.8	21	23.7	11.5	21	-	39.6
TKC-PC8-01	8	R1/8	17.5	13.6	27.5	15.8	8	14	5	16
TKC-PC8-02	8	R1/4	17.5	13.6	24.4	15.8	9	14	6	16
TKC-PC8-03	8	R3/8	17.5	13.6	21	19.1	9.5	17	6	21.7
TKC-PC8-04	8	R1/2	17.5	13.6	21	23.7	11.5	21	6	38.6
TKC-PC10-01	10	R1/8	19.7	15.7	29.4	19.1	8	17	5	22
TKC-PC10-02	10	R1/4	19.7	15.7	30.4	19.1	9	17	6	26.5
TKC-PC10-03	10	R3/8	19.7	15.7	26.1	19.1	9.5	17	8	26.8
TKC-PC10-04	10	R1/2	19.7	15.7	23.8	23.7	11.5	21	8	39.5
TKC-PC12-01	12	R1/8	18.7	17.8	29.2	21.4	8	19	5	26.2
TKC-PC12-02	12	R1/4	18.7	17.8	30.2	21.4	9	19	6	26.5
TKC-PC12-03	12	R3/8	18.7	17.8	28.2	21.4	9.5	19	8	29.5
TKC-PC12-04	12	R1/2	18.7	17.8	25.7	23.7	11.5	21	8	37.1
TKC-PC14-03	14	R3/8	20.5	20.8	31.8	23.7	9.5	21	-	39.8
TKC-PC14-04	14	R1/2	20.5	20.8	29.8	23.7	11.5	21	-	44.4
TKC-PC16-03	16	R3/8	21.5	22.8	33.8	26.9	9.5	24	-	44.9
TKC-PC16-04	16	R1/2	21.5	22.8	32.8	26.9	11.5	24	-	51.8
TKC-PC16-06	16	R3/4	21.5	22.8	31.8	30.4	12	27	-	-

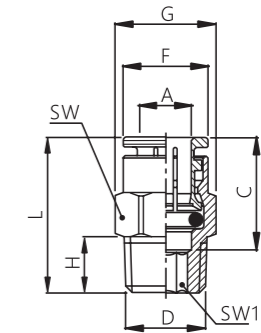

## TKC-PC-G...型快插管接头



尺寸表

型号	A	D	C	F	L	G	H	SW	SW1	重量 (g)
TKC-PC4-M5	4	M5	13.5	8	18.7	8.9	3.6	8	-	3.6
TKC-PC4-01G	4	G1/8	13.5	8	17.6	11.8	5	10	2.5	8.8
TKC-PC4-02G	4	G1/4	13.5	8	17.5	16	6.5	12	-	9
TKC-PC6-M5	6	M5	17	11.8	21.5	13.5	3.6	12	-	10.1
TKC-PC6-01G	6	G1/8	17	11.8	21.2	13.5	5	12	4	10.7
TKC-PC6-02G	6	G1/4	17	11.8	21.8	16	6.5	12	4	13.1
TKC-PC6-03G	6	G3/8	17	11.8	18.2	21.5	7.5	19	-	14
TKC-PC6-04G	8	G1/2	17	11.8	20	28	9	24	-	37.4
TKC-PC8-01G	8	G1/8	17.5	13.6	24.6	16	5	14	5	16.4
TKC-PC8-02G	8	G1/4	17.5	13.6	23	16	6.5	14	6	15.2
TKC-PC8-03G	8	G3/8	17.5	13.6	21	21.5	7.5	19	6	15.7
TKC-PC8-04G	10	G1/2	17.5	13.6	21	28	9	24	-	39.6
TKC-PC10-01G	10	G1/8	19.7	15.7	27.3	19.1	5	17	5	22.4
TKC-PC10-02G	10	G1/4	19.7	15.7	28.5	19.1	6.5	17	6	25.1
TKC-PC10-03G	10	G3/8	19.7	15.7	26	21.5	7.5	19	8	30
TKC-PC10-04G	12	G1/2	19.7	15.7	23.5	28	9	24	8	39.7
TKC-PC12-01G	12	G1/8	18.7	17.8	27	21.5	5	19	5	25.1
TKC-PC12-02G	12	G1/4	18.7	17.8	29	21.5	6.5	19	6	25.5
TKC-PC12-03G	12	G3/8	18.7	17.8	29.5	21.5	7.5	19	8	28
TKC-PC12-04G	14	G1/2	18.7	17.8	27	28	9	24	-	36.4
TKC-PC14-03G	14	G3/8	20.5	20.8	30.5	24	7.5	21	-	40
TKC-PC14-04G	16	G1/2	20.5	20.8	28.5	28	9	24	-	48.1
TKC-PC16-03G	16	G3/8	21.5	22.8	32	28	7.5	24	-	49
TKC-PC16-04G	16	G1/2	21.5	22.8	33.5	28	9	24	-	60.6

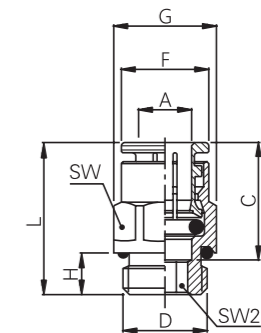

## TKC-POC...型快插管接头

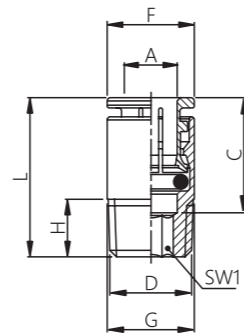

尺寸表

型号	A	D	F	L	C	H	G	SW1	重量 (g)
TKC-POC4-01	4	R1/8	8	17	13.5	8	10	2.5	6.6
TKC-POC6-01	6	R1/8	11.8	22.4	17	8	11.8	4	8.2
TKC-POC6-02	6	R1/4	11.8	21.2	17	9	14	4	14.9
TKC-POC8-01	8	R1/8	13.6	26.5	17.5	8	13.8	5	13.9
TKC-POC8-02	8	R1/4	13.6	24.4	17.5	9	13.8	6	14
TKC-POC8-03	8	R3/8	13.6	21	17.5	9.5	16.8	6	19.7
TKC-POC10-02	10	R1/4	15.7	29	19.7	9	16	6	25.2
TKC-POC10-03	10	R3/8	15.7	26.1	19.7	9.5	16.8	8	23.4
TKC-POC12-02	12	R1/4	17.8	29.2	18.7	9	18.5	6	22.6
TKC-POC12-03	12	R3/8	17.8	27.2	18.7	9.5	18.5	8	26.1
TKC-POC12-04	12	R1/2	17.8	25.7	18.7	11.5	21	8	35.9

## TKC-PCF...型快插管接头

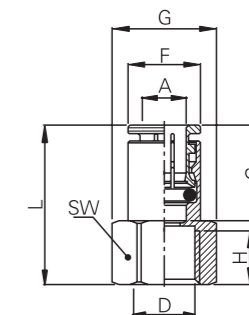

尺寸表

型号	A	D	C	F	L	G	H	SW	重量 (g)
TKC-PCF4-M5	4	M5	13.5	8	20.6	8.9	6	8	4.6
TKC-PCF4-01	4	G1/8	13.5	8	22.6	13.5	8	12	9.2
TKC-PCF4-02	4	G1/4	13.5	8	25.6	19.1	11	17	16.9
TKC-PCF6-M5	6	M5	17	11.8	23.2	13.5	6	12	12.6
TKC-PCF6-01	6	G1/8	17	11.8	26.4	13.5	8	12	13.7
TKC-PCF6-02	6	G1/4	17	11.8	29.4	19.1	11	17	21.3
TKC-PCF6-03	6	G3/8	17	11.8	30	21.4	11.5	19	22.1
TKC-PCF6-04	6	G1/2	17	11.8	31	26.9	12.5	24	23.4
TKC-PCF8-01	8	G1/8	17.5	13.6	27.5	15.8	8	14	18.7
TKC-PCF8-02	8	G1/4	17.5	13.6	29.5	19.1	11	17	23.4
TKC-PCF8-03	8	G3/8	17.5	13.6	30	21.4	11.5	19	24.9
TKC-PCF8-04	8	G1/2	17.5	13.6	31	26.9	12.5	24	35.9
TKC-PCF10-01	10	G1/8	19.7	15.7	29.6	19.1	8	17	27.5
TKC-PCF10-02	10	G1/4	19.7	15.7	31.6	19.1	11	17	25.8
TKC-PCF10-03	10	G3/8	19.7	15.7	32.1	21.4	11.5	19	27.5
TKC-PCF10-04	10	G1/2	19.7	15.7	33.1	26.9	12.5	24	38.8
TKC-PCF12-01	12	G1/8	18.7	17.8	27.7	21.4	8	19	-
TKC-PCF12-02	12	G1/4	18.7	17.8	30.7	21.4	11	19	33.5
TKC-PCF12-03	12	G3/8	18.7	17.8	31.2	21.4	11.5	19	31.2
TKC-PCF12-04	12	G1/2	18.7	17.8	32.2	26.9	12.5	24	37.8

## TKC-POC-G...型快插管接头

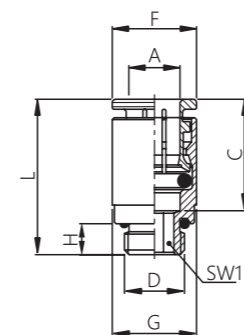

尺寸表

型号	A	D	C	F	L	G	H	SW1	重量 (g)
TKC-POC4-M5	4	M5	13.5	8	18.2	8	3.6	2.5	3.6
TKC-POC4-01G	4	G1/8	13.5	8	17.6	11.8	5	2.5	6.9
TKC-POC6-M5	6	M5	17	11.8	26.5	11.8	3.6	2.5	9.4
TKC-POC6-01G	6	G1/8	17	11.8	21.2	11.8	5	4	8.7
TKC-POC6-02G	6	G1/4	17	11.8	21.8	16	6.5	4	13.5
TKC-POC8-01G	8	G1/8	17.5	13.6	26.5	13.8	5	5	12.6
TKC-POC8-02G	8	G1/4	17.5	13.6	23.2	16	6.5	6	14.7
TKC-POC8-03G	8	G3/8	17.5	13.6	21	19	7	6	-
TKC-POC10-02G	10	G1/2	19.7	15.7	28.6	16	6.5	6	19.8
TKC-POC10-03G	10	G3/8	19.7	15.7	26.1	19	7	8	-
TKC-POC12-02G	12	G1/4	18.7	17.8	28	18.5	6.5	6	-
TKC-POC12-03G	12	G3/8	18.7	17.8	27.2	19	7	8	-
TKC-POC12-04G	12	G1/2	18.7	17.8	25.7	24	9	8	-

## TKC-PMF...型快插管接头

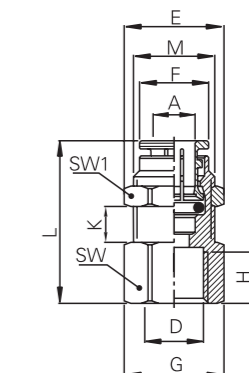

尺寸表

型号	A	D	F	C	E	M	H	G	L	SW	SW1	K	重量(g)
PMF4-M5	4	M5	8	13.5	6	M10×1	6	13.5	21.2	12	14	7	4.5
PMF4-01	4	G1/8	8	13.5	15.8	M10×1	8	13.5	25.1	12	14	7	9
PMF4-02	4	G1/4	8	13.5	15.8	M10×1	11	19.1	28.5	17	14	7	17
PMF6-01	6	G1/8	11.8	17	19.1	M14×1	8	17.9	27.4	16	17	9.5	12.4
PMF6-02	6	G1/4	11.8	17	19.1	M14×1	11	17.9	31	16	17	9	21
PMF8-01	8	G1/8	13.6	17.5	21.4	M16×1	8	19.1	27.5	17	19	9	17
PMF8-02	8	G1/4	13.6	17.5	21.4	M16×1	11	19.1	29.5	17	19	9	23.7
PMF10-03	10	G3/8	15.7	19.7	24.9	M18×1	11.5	23.7	34	21	22	9	26
PMF10-04	10	G1/2	15.7	19.7	24.9	M18×1	12.5	26.9	35	24	22	9	37.1
PMF12-03	12	G3/8	17.8	18.7	26.9	M20×1	11.5	26.9	31.8	24	24	8.5	31.3
PMF12-04	12	G1/2	17.8	18.7	26.9	M20×1	12.5	26.9	31.8	24	24	7.5	37.8

## TKC-PL...型快插管接头



尺寸表

型号	A	D	C	F	M	E	H	G	SW	SW1	重量(g)
TKC-PL4-01	4	R1/8	13.5	8	16.6	17.6	8	11.3	6	10	10
TKC-PL4-02	4	R1/4	13.5	8	16.6	18.6	9	15.8	6	14	17.4
TKC-PL6-01	6	R1/8	17	11.8	22	21	8	13.5	-	12	21
TKC-PL6-02	6	R1/4	17	11.8	22	22	9	15.8	-	14	23.7
TKC-PL6-03	6	R3/8	17	11.8	22	22.5	9.5	19.1	-	17	29.5
TKC-PL6-04	6	R1/2	17	11.8	22	24.5	11.5	23.7	-	21	35.7
TKC-PL8-01	8	R1/8	17.5	13.6	22.8	21.3	8	13.5	11.5	12	24.6
TKC-PL8-02	8	R1/4	17.5	13.6	22.8	22.3	9	15.8	11.5	14	27
TKC-PL8-03	8	R3/8	17.5	13.6	22.8	22.8	9.5	19.1	11.5	17	32.7
TKC-PL8-04	8	R1/2	17.5	13.6	22.8	24.8	11.5	23.7	11.5	21	43.1
TKC-PL10-01	10	R1/8	19.7	15.7	26.5	26.4	8	15.8	12	14	33.9
TKC-PL10-02	10	R1/4	19.7	15.7	26.5	27.4	9	15.8	12	14	34.1
TKC-PL10-03	10	R3/8	19.7	15.7	26.5	27.9	9.5	19.1	12	17	38.7
TKC-PL10-04	10	R1/2	19.7	15.7	26.5	29.9	11.5	23.7	12	21	46.8
TKC-PL12-01	12	R1/8	18.7	17.8	27.8	27.9	8	19.1	14	14	43.3
TKC-PL12-02	12	R1/4	18.7	17.8	27.8	28.9	9	19.1	14	14	44.1
TKC-PL12-03	12	R3/8	18.7	17.8	27.8	29.4	9.5	19.1	14	17	48
TKC-PL12-04	12	R1/2	18.7	17.8	27.8	31.4	11.5	23.7	14	21	53.1
TKC-PL14-03	14	R3/8	20.5	20.8	30	34.4	9.5	23.7	19	17	96.9
TKC-PL14-04	14	R1/2	20.5	20.8	30	36.4	11.5	23.7	19	17	83.6
TKC-PL16-03	16	R3/8	21.5	22.8	32.3	34.4	9.5	23.7	19	21	88.3
TKC-PL16-04	16	R1/2	21.5	22.8	32.3	36.4	11.5	23.7	19	21	94.3
TKC-PL16-06	16	R3/4	21.5	22.8	32.3	37.4	12	29.2	19	26	-

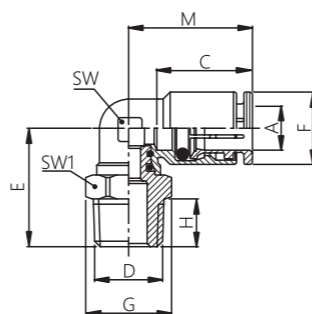

## TKC-DL...型快插管接头



尺寸表

型号	A	D	F	C	M	E	G	H	SW	SW1	重量(g)
TKC-PL4-01	4	R1/8	8	13.5	17.6	16	11.5	8	10	8	
TKC-PL4-02	4	R1/4	8	13.5	17.6	17	16	9	14	8	
TKC-PL6-01	6	R1/8	11.8	17	22.3	18.8	13.5	8	12	12	
TKC-PL6-02	6	R1/4	11.8	17	22.3	19.8	16	9	14	12	
TKC-PL8-01	8	R1/8	13.6	17.5	24.5	20	16	8	14	14	
TKC-PL8-02	8	R1/4	13.6	17.5	24.5	21	16	9	14	14	

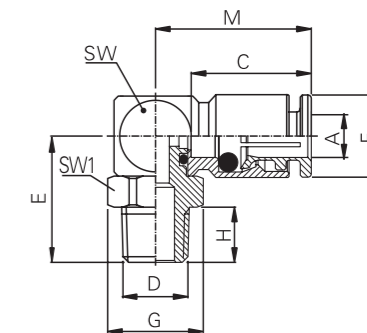

## TKC-PL-G...型快插管接头



尺寸表

型号	A	D	C	F	M	E	H	G	SW	SW1	重量(g)
TKC-PL4-M5	4	M5	13.5	8	16.6	18	3.6	8.9	6	8	8.1
TKC-PL4-01G	4	G1/8	13.5	8	16.6	15	5	13.5	6	12	10.9
TKC-PL4-02G	4	G1/4	13.5	8	16.6	16.5	6.5	18	6	16	17
TKC-PL6-M5	6	M5	17	11.8	22	19	3.6	11.3	-	10	16.2
TKC-PL6-01G	6	G1/8	17	11.8	22	18	5	13.5	-	12	20
TKC-PL6-02G	6	G1/4	17	11.8	22	19.5	6.5	18	-	16	22.9
TKC-PL6-03G	6	G3/8	17	11.8	22	21	7.5	21.5	-	19	30.1
TKC-PL6-04G	6	G1/2	17	11.8	22	23	9	28	11.5	24	41
TKC-PL8-01G	8	G1/8	17.5	13.6	22.8	18.5	5	13.5	11.5	12	21.6
TKC-PL8-02G	8	G1/4	17.5	13.6	22.8	20	6.5	18	11.5	16	26.9
TKC-PL8-03G	8	G3/8	17.5	13.6	22.8	21.5	7.5	21.5	11.5	19	33
TKC-PL8-04G	8	G1/2	17.5	13.6	22.8	23.5	9	28	12	24	34.1
TKC-PL10-01G	10	G1/8	19.7	15.7	26.5	23.5	5	16	12	14	29.4
TKC-PL10-02G	10	G1/4	19.7	15.7	26.5	25.5	6.5	18	12	16	35.1
TKC-PL10-03G	10	G3/8	19.7	15.7	26.5	26	7.5	21.5	12	19	37.5
TKC-PL10-04G	10	G1/2	19.7	15.7	26.5	28.5	9	28	14	24	52.4
TKC-PL12-01G	12	G1/8	18.7	17.8	27.8	24.9	5	18	14	16	38
TKC-PL12-02G	12	G1/4	18.7	17.8	27.8	26.9	6.5	18	14	16	41.4
TKC-PL12-03G	12	G3/8	18.7	17.8	27.8	28	7.5	21.5	14	19	45.9
TKC-PL12-04G	12	G1/2	18.7	17.8	27.8	30	9	28	19	24	61.2
TKC-PL14-03G	14	G3/8	20.5	20.8	30	31.9	7.5	21.5	19	19	93.9
TKC-PL14-04G	14	G1/2	20.5	20.8	30	34.9	9	28	19	24	85.7
TKC-PL16-03G	16	G3/8	21.5	22.8	32.3	31.9	7.5	21.5	19	19	
TKC-PL16-04G	16	G1/2	21.5	22.8	32.3	34.9	9	28	19	24	

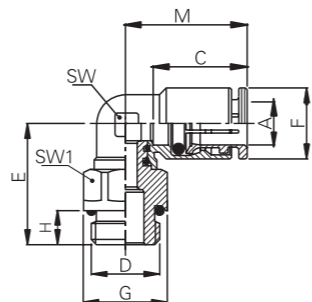

## TKC-DL-G...型快插管接头



尺寸表

型号	A	D	F	C	M	E	G	H	SW	SW1	重量(g)
TKC-PL4-01G	4	G1/8	8	13.5	17.6	14.5	13.5	5	12	8	
TKC-PL4-02G	4	G1/4	8	13.5	17.6	15.5	18	6	16	8	
TKC-PL6-01G	6	G1/8	11.8	17	22.3	16	13.5	5	12	12	
TKC-PL6-02G	6	G1/4	11.8	17	22.3	17	18	6	16	12	
TKC-PL8-01G	8	G1/8	13.6	17.5	24.5	17	16	5	14	14	
TKC-PL8-02G	8	G1/4	13.6	17.5	24.5	18	18	6	16	14	

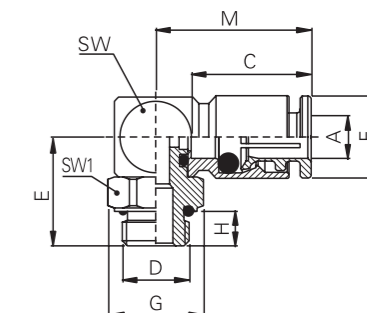

## TKC-PLF...型快插管接头



尺寸表

型号	A	D	C	F	M	E	H	G	SW	SW1	重量(g)
TKC-PLF4-M5	4	M5	13.5	8	16.6	17.3	6	11.3	6	10	9.9
TKC-PLF4-01	4	R1/8	13.5	8	16.6	20.3	8	13.5	6	12	11.3
TKC-PLF4-02	6	R1/4	13.5	8	16.6	23.4	11	19.1	6	17	20.4
TKC-PLF6-01	6	R1/8	17	11.8	22	18.3	8	15.8	-	14	22.4
TKC-PLF6-02	6	R1/4	17	11.8	22	20.6	11	19.1	-	17	26.9
TKC-PLF6-03	6	R3/8	17	11.8	22	21.5	11.5	21.4	-	19	29.2
TKC-PLF6-04	6	R1/2	17	11.8	22	22.5	12.5	26.9	-	24	37.7
TKC-PLF8-01	8	R1/8	17.5	13.6	22.8	18.6	8	15.8	11.5	14	28.5
TKC-PLF8-02	8	R1/4	17.5	13.6	22.8	20.9	11	19.1	11.5	17	31.5
TKC-PLF8-03	8	R3/8	17.5	13.6	22.8	21.8	11.5	21.4	11.5	19	33.6
TKC-PLF8-04	8	R1/2	17.5	13.6	22.8	22.8	12.5	26.9	11.5	24	-
TKC-PLF10-01	10	R1/8	19.7	15.7	26.5	23.7	8	15.8	12	14	33
TKC-PLF10-02	10	R1/4	19.7	15.7	26.5	26	11	19.1	12	17	35.9
TKC-PLF10-03	10	R3/8	19.7	15.7	26.5	27	11.5	21.4	12	19	38.9
TKC-PLF10-04	10	R1/2	19.7	15.7	26.5	27.9	12.5	26.9	12	24	47.6
TKC-PLF12-01	12	R1/8	18.7	17.8	27.8	25.2	8	19.1	14	17	-
TKC-PLF12-02	12	R1/4	18.7	17.8	27.8	27.5	11	19.1	14	17	-
TKC-PLF12-03	12	R3/8	18.7	17.8	27.8	28.5	11.5	21.4	14	19	-
TKC-PLF12-04	12	R1/2	18.7	17.8	27.8	29.4	12.5	26.9	14	24	-

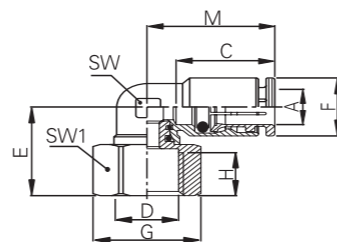

## TKC-PLL...型快插管接头



尺寸表

型号	A	D	C	F	M	E	H	G	SW	SW1	重量(g)
TKC-PLL4-01	4	R1/8	13.5	8	16.6	37.6	8	11.3	6	10	-
TKC-PLL4-02	4	R1/4	13.5	8	16.6	38.6	9	15.8	6	14	-
TKC-PLL6-01	6	R1/8	17	11.8	22	41	8	13.5	-	12	33
TKC-PLL6-02	6	R1/4	17	11.8	22	42	9	15.8	-	14	41.8
TKC-PLL6-03	6	R3/8	17	11.8	22	42.5	9.5	19.1	-	17	-
TKC-PLL6-04	6	R1/2	17	11.8	22	44.5	11.5	23.7	-	21	-
TKC-PLL8-01	8	R1/8	17.5	13.6	22.8	41.3	8	13.5	11.5	12	37.2
TKC-PLL8-02	8	R1/4	17.5	13.6	22.8	42.3	9	15.8	11.5	14	45.4
TKC-PLL8-03	8	R3/8	17.5	13.6	22.8	42.8	9.5	19.1	11.5	17	-
TKC-PLL8-04	8	R1/2	17.5	13.6	22.8	44.8	11.5	23.7	11.5	21	-
TKC-PLL10-01	10	R1/8	19.7	15.7	26.5	46.4	8	15.8	12	14	-
TKC-PLL10-02	10	R1/4	19.7	15.7	26.5	47.4	9	15.8	12	14	53.9
TKC-PLL10-03	10	R3/8	19.7	15.7	26.5	47.9	9.5	19.1	12	17	65
TKC-PLL10-04	10	R1/2	19.7	15.7	26.5	49.9	11.5	23.7	12	21	-
TKC-PLL12-01	12	R1/8	18.7	17.8	27.8	47.9	8	19.1	14	14	-
TKC-PLL12-02	12	R1/4	18.7	17.8	27.8	48.9	9	19.1	14	14	-
TKC-PLL12-03	12	R3/8	18.7	17.8	27.8	49.4	9.5	19.1	14	17	75
TKC-PLL12-04	12	R1/2	18.7	17.8	27.8	51.4	11.5	23.7	14	21	-

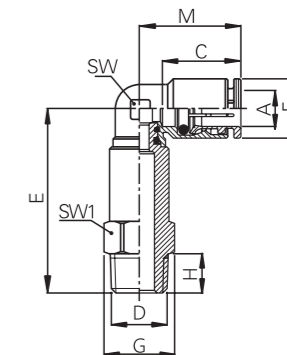

## TKC-PLM...型快插管接头



尺寸表

型号	A	F	C	M	L	E	SW	SW1	K(max)	重量(g)
TKC-PLM6	6	11.8	17	M14×1	30.5	22	17	-	7	-
TKC-PLM8	8	13.6	17.5	M16×1	31	22.8	19	11.5	7	-
TKC-PLM10	10	15.7	19.5	M18×1	38	26.5	22	12	9	-
TKC-PLM12	12	17.8	18.7	M20×1	39.5	27.8	24	14	8	-

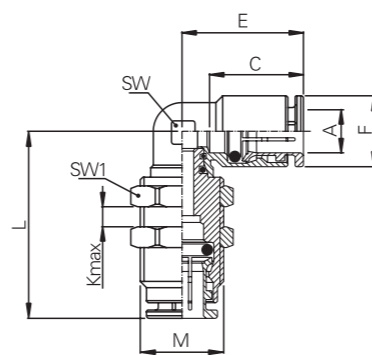

## TKC-PLL-G...型快插管接头



尺寸表

型号	A	D	C	F	M	E	G	H	SW	SW1	重量(g)
TKC-PLL4-M5	4	M5	13.5	8	16.6	31.6	8.9	3.6	6	8	-
TKC-PLL4-01G	4	G1/8	13.5	8	16.6	37.6	13.5	5	6	12	-
TKC-PLL4-02G	4	G1/4	13.5	8	16.6	37.1	16	7	6	12	-
TKC-PLL6-M5	6	M5	17	11.8	22	35	11.3	3.6	-	10	25.5
TKC-PLL6-01G	6	G1/8	17	11.8	22	41	13.8	5	-	12	-
TKC-PLL6-02G	6	G1/4	17	11.8	22	41	16	7	-	12	-
TKC-PLL6-03G	6	G3/8	17	11.8	22	40.5	21.4	7	-	19	-
TKC-PLL6-04G	8	G1/2	17	11.8	22	42.9	26.9	9	-	24	-
TKC-PLL8-01G	8	G1/8	17.5	13.6	22.8	41.3	13.8	5	11.5	12	37.2
TKC-PLL8-02G	8	G1/4	17.5	13.6	22.8	41.3	16	7	11.5	12	45.5
TKC-PLL8-03G	8	G3/8	17.5	13.6	22.8	40.8	21.4	7.5	11.5	19	-
TKC-PLL8-04G	8	G1/2	17.5	13.6	22.8	43.2	26.9	9	11.5	24	-
TKC-PLL10-01G	10	G1/8	19.7	15.7	26.5	43.4	19.1	5	12	14	-
TKC-PLL10-02G	10	G1/4	19.7	15.7	26.5	45.4	19.1	7	12	16	52.2
TKC-PLL10-03G	10	G3/8	19.7	15.7	26.5	45.9	21.4	7	12	19	-
TKC-PLL10-04G	10	G1/2	19.7	15.7	26.5	48.3	26.9	9	12	24	-
TKC-PLL12-01G	12	G1/8	18.7	17.8	27.8	45.9	17.9	5	14	16	-
TKC-PLL12-02G	12	G1/4	18.7	17.8	27.8	46.9	17.9	7	14	16	-
TKC-PLL12-03G	12	G3/8	18.7	17.8	27.8	47.4	21.4	7.5	14	19	-
TKC-PLL12-04G	12	G1/2	18.7	17.8	27.8	49.9	26.9	9	14	24	-

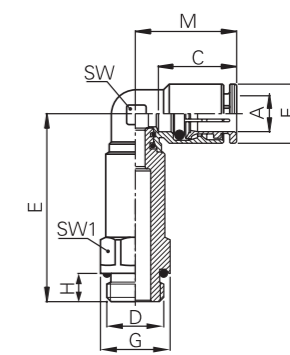



## TKC-PLV...型快插管接头135°

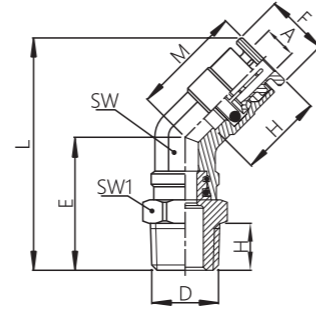

尺寸表

型号	A	D	C	F	M	E	L	SW	SW1	重量(g)
TKC-PLV6-01	6	R1/8	17	11.8	20.5	19.5	32.5	11	12	-
TKC-PLV6-02	6	R1/4	17	11.8	20.5	21	34.5	11	14	-
TKC-PLV8-01	8	R1/8	17.5	13.6	22.5	19.5	32.5	11	14	-
TKC-PLV8-02	8	R1/4	17.5	13.6	22.5	21	34.5	11	12	-
TKC-PLV8-03	8	R3/8	17.5	13.6	22.5	22.5	35	11	17	-
TKC-PLV10-02	10	R1/4	19.7	15.7	26.5	22.5	39.5	15	14	-
TKC-PLV10-03	10	R3/8	19.7	15.7	26.5	23.5	39.5	15	17	-
TKC-PLV10-04	10	R1/2	19.7	15.7	26.5	25	40	15	21	-
TKC-PLV12-02	12	R1/4	18.7	17.8	26.5	22.5	40.5	15	17	-
TKC-PLV12-03	12	R3/8	18.7	17.8	26.5	23.5	40.5	15	17	-
TKC-PLV12-04	12	R1/2	18.7	17.8	26.5	25	41	15	21	-

## TKC-PB...型快插管接头

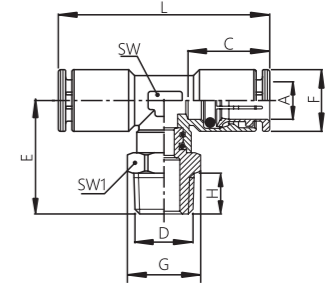

尺寸表

型号	A	D	C	F	L	E	H	G	SW	SW1	重量(g)
TKC-PB4-01	4	R1/8	13.5	8	32.4	17.6	8	11.3	6	10	11.9
TKC-PB4-02	4	R1/4	13.5	8	32.4	18.6	9	15.8	6	14	17.9
TKC-PB6-01	6	R1/8	17	11.8	43.2	26	8	13.5	10	12	33.1
TKC-PB6-02	6	R1/4	17	11.8	43.2	27	9	15.8	10	14	34
TKC-PB6-03	6	R3/8	17	11.8	43.2	27.5	9.5	19.1	10	17	36.2
TKC-PB6-04	6	R1/2	17	11.8	43.2	29.5	11.5	23.7	10	21	45.4
TKC-PB8-01	8	R1/8	17.5	13.6	44.6	24	8	13.5	12	12	41.3
TKC-PB8-02	8	R1/4	17.5	13.6	44.6	25	9	15.8	12	14	39.5
TKC-PB8-03	8	R3/8	17.5	13.6	44.6	25.5	9.5	19.1	12	17	47
TKC-PB8-04	8	R1/2	17.5	13.6	44.6	27.5	11.5	23.7	12	21	54.6
TKC-PB10-01	10	R1/8	19.7	15.7	54.4	25.8	8	15.8	12.5	14	43.2
TKC-PB10-02	10	R1/4	19.7	15.7	54.4	26.8	9	15.8	12.5	14	47.2
TKC-PB10-03	10	R3/8	19.7	15.7	54.4	27.3	9.5	19.1	12.5	17	50
TKC-PB10-04	10	R1/2	19.7	15.7	54.4	29.3	11.5	23.7	12.5	21	56.7
TKC-PB12-01	12	R1/8	18.7	17.8	55	27.9	8	19.1	14	14	63.1
TKC-PB12-02	12	R1/4	18.7	17.8	55	28.9	9	19.1	14	14	62.8
TKC-PB12-03	12	R3/8	18.7	17.8	55	29.4	9.5	19.1	14	17	70.1
TKC-PB12-04	12	R1/2	18.7	17.8	55	31.4	11.5	23.7	14	21	72.4
TKC-PB14-03	14	R3/8	20.5	20.8	60.4	34.4	9.5	23.7	19	17	126.7
TKC-PB14-04	14	R1/2	20.5	20.8	60.4	36.4	11.5	23.7	19	17	126
TKC-PB16-03	16	R3/8	21.5	22.8	66	34.4	9.5	23.7	19	21	126.9
TKC-PB16-04	16	R1/2	21.5	22.8	66	36.4	11.5	23.7	19	21	130.4

## TKC-PLV-G...型快插管接头135°

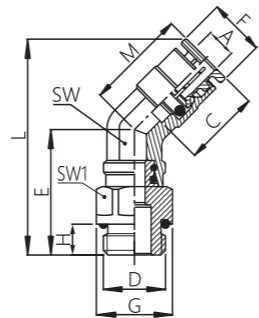

尺寸表

型号	A	D	C	F	M	E	G	L	H	SW	SW1	重量(g)
TKC-PLV6-01G	6	G1/8	17	11.8	20.5	19.5	13.8	32.5	5	11	12	-
TKC-PLV6-02G	6	G1/4	17	11.8	20.5	21	16	34.5	7	11	12	-
TKC-PLV8-01G	8	G1/8	17.5	13.6	22.5	19.5	13.8	32.5	5	11	12	-
TKC-PLV8-02G	8	G1/4	17.5	13.6	22.5	21	16	34.5	7	11	12	-
TKC-PLV8-03G	8	G3/8	17.5	13.6	22.5	22.5	21.4	35	7	11	19	-
TKC-PLV10-02G	10	G1/4	19.7	15.7	26.5	22.5	17.9	39.5	7	15	16	-
TKC-PLV10-03G	10	G3/8	19.7	15.7	26.5	23.5	21.4	39.5	7	15	19	-
TKC-PLV10-04G	10	G1/2	18.7	15.7	26.5	25	26.9	40	9	15	24	-
TKC-PLV12-02G	12	G1/4	18.7	17.8	26.5	22.5	17.9	40.5	7	15	16	-
TKC-PLV12-03G	12	G3/8	18.7	17.8	26.5	23.5	21.4	40.5	7	15	19	-
TKC-PLV12-04G	12	G1/2	18.7	17.8	26.5	25	26.9	41	9	15	24	-

## TKC-PB-G...型快插管接头

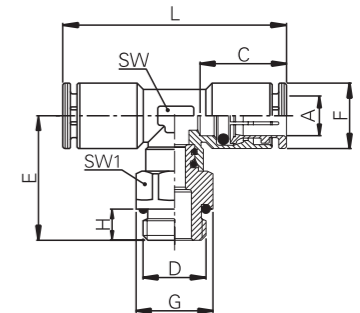

尺寸表

型号	A	D	C	F	L	E	G	H	SW1	SW	重量(g)
TKC-PB4-M5	4	M5	13.5	8	32.4	18.6	8.9	3.6	8	6	9.9
TKC-PB4-01G	4	G1/8	13.5	8	32.4	17.1	13.5	5	12	6	13.2
TKC-PB4-02G	4	G1/4	13.5	8	32.4	18.6	16	7	12	6	18.2
TKC-PB6-M5	6	M5	17	11.8	43.2	23.1	11.3	3.6	10	10	25.3
TKC-PB6-01G	6	G1/8	17	11.8	43.2	26	13.8	5	12	10	27.4
TKC-PB6-02G	6	G1/4	17	11.8	43.2	26	16	7	12	10	31.5
TKC-PB6-03G	6	G3/8	17	11.8	43.2	26.3	21.4	7	19	10	-
TKC-PB6-04G	8	G1/2	17	11.8	43.2	28	26.9	9	24	10	-
TKC-PB8-01G	8	G1/8	17.5	13.6	44.6	24	13.8	5	12	12	34.2
TKC-PB8-02G	8	G1/4	17.5	13.6	44.6	24	16	7	12	12	39.2
TKC-PB8-03G	8	G3/8	17.5	13.6	44.6	24.3	21.4	7	19	12	47.7
TKC-PB8-04G	8	G1/2	17.5	13.6	44.6	26	26.9	9	24	12	-
TKC-PB10-01G	10	G1/8	19.7	15.7	54.4	22.8	15.8	5	14	12.5	-
TKC-PB10-02G	10	G1/4	19.7	15.7	54.4	26.1	17.9	7	16	12.5	48.8
TKC-PB10-03G	10	G3/8	19.7	15.7	54.4	26.1	21.4	7	19	12.5	52.5
TKC-PB10-04G	10	G1/2	19.7	15.7	54.4	27.8	26.9	9	24	12.5	62.6
TKC-PB12-01G	12	G1/8	18.7	17.8	55	24.9	17.9	5	16	14	-
TKC-PB12-02G	12	G1/4	18.7	17.8	55	28.2	17.9	7	16	14	67.2
TKC-PB12-03G	12	G3/8	18.7	17.8	55	28.2	21.4	7	19	14	66.6
TKC-PB12-04G	12	G1/2	18.7	17.8	55	29.9	26.9	9	24	14	77.2
TKC-PB14-03G	14	G3/8	20.5	20.8	60.4	33.2	23.7	7	21	19	-
TKC-PB14-04G	14	G1/2	20.5	20.8	60.4	34.9	26.9	9	24	19	-
TKC-PB16-03G	16	G3/8	21.5	22.8	66	33.2	23.7	7	21	19	-
TKC-PB16-04G	16	G1/2	21.5	22.8	66	34.9	26.9	9	24	19	-

## TKC-PD...型快插管接头



尺寸表

型号	A	D	C	F	H	E	L	M	SW	SW1	重量(g)
TKC-PD4-01	4	R1/8	13.5	8	8	17.6	33.8	16.2	6	10	13.3
TKC-PD4-02	4	R1/4	13.5	8	9	18.6	34.8	16.2	6	14	18.8
TKC-PD6-01	6	R1/8	17	11.8	8	26	47.6	21.6	10	12	31.5
TKC-PD6-02	6	R1/4	17	11.8	9	27	48.6	21.6	10	14	34.4
TKC-PD6-03	6	R3/8	17	11.8	9.5	27.5	49.1	21.6	10	17	-
TKC-PD6-04	6	R1/2	17	11.8	11.5	29.5	51.1	21.6	10	21	-
TKC-PD8-01	8	R1/8	17.5	13.6	8	24	46.3	22.3	12	12	37
TKC-PD8-02	8	R1/4	17.5	13.6	9	25	47.3	22.3	12	14	38.3
TKC-PD8-03	8	R3/8	17.5	13.6	9.5	25.5	47.8	22.3	12	17	44.1
TKC-PD8-04	8	R1/2	17.5	13.6	11.5	27.5	49.8	22.3	12	21	58.7
TKC-PD10-01	10	R1/8	19.7	15.7	8	25.8	53	27.2	12.5	14	44.9
TKC-PD10-02	10	R1/4	19.7	15.7	9	26.8	54	27.2	12.5	14	47.2
TKC-PD10-03	10	R3/8	19.7	15.7	9.5	27.3	54.5	27.2	12.5	17	52.7
TKC-PD10-04	10	R1/2	19.7	15.7	11.5	29.3	56.5	27.2	12.5	21	60.1
TKC-PD12-01	12	R1/8	18.7	17.8	8	27.9	55.4	27.5	14	14	-
TKC-PD12-02	12	R1/4	18.7	17.8	9	28.9	56.4	27.5	14	14	65.1
TKC-PD12-03	12	R3/8	18.7	17.8	9.5	29.4	56.9	27.5	14	17	68.6
TKC-PD12-04	12	R1/2	18.7	17.8	11.5	31.4	58.9	27.5	14	21	73.7

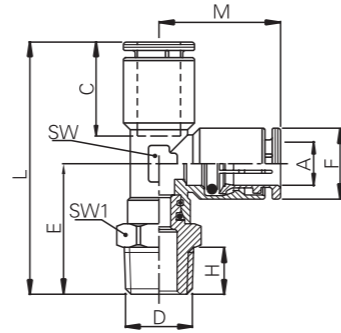

## TKC-PH...型快插管接头



尺寸表

型号	A	D	C	F	L	E	B	SW1	重量(g)
TKC-PH4-01	4	R1/8	13.5	8	14.5	22.4	25	12	16.5
TKC-PH4-02	4	R1/4	13.5	8	17.5	22.9	29	15	33.7
TKC-PH6-01	6	R1/8	17	11.8	14.5	24.2	25	12	27.9
TKC-PH6-02	6	R1/4	17	11.8	17.5	26.5	29	15	38.7
TKC-PH6-03	6	R3/8	17	11.8	19.5	28.5	33	21	61.7
TKC-PH6-04	6	R1/2	17	11.8	22	30.5	36	24	-
TKC-PH8-01	8	R1/8	17.5	13.6	14.5	25.9	25	12	27.9
TKC-PH8-02	8	R1/4	17.5	13.6	17.5	26.9	29	15	36.6
TKC-PH8-03	8	R3/8	17.5	13.6	19.5	29.3	33	21	61.4
TKC-PH8-04	8	R1/2	17.5	13.6	22	30.8	36	24	89.9
TKC-PH10-01	10	R1/8	19.7	15.7	15.5	30.5	25	12	38.6
TKC-PH10-02	10	R1/4	19.7	15.7	18.5	31.5	29	15	47.9
TKC-PH10-03	10	R3/8	19.7	15.7	19.5	32.6	33	21	72.5
TKC-PH10-04	10	R1/2	19.7	15.7	22	33.5	36	24	86.8
TKC-PH12-02	12	R1/4	18.7	17.8	19.5	30	29	15	47.9
TKC-PH12-03	12	R3/8	18.7	17.8	20.5	32.2	33	21	69.8
TKC-PH12-04	12	R1/2	18.7	17.8	22	33.5	36	24	85.8
TKC-PH16-04	16	R1/2	21.5	22.8	25.2	40.8	36	24	-

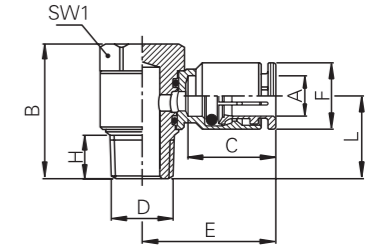

## TKC-PD-G...型快插管接头



尺寸表

型号	A	D	C	F	L	E	G	M	H	SW1	SW	重量(g)
TKC-PD4-M5	4	M5	13.5	8	34.8	18.6	8.9	16.2	3.6	8	6	9.9
TKC-PD4-01G	4	G1/8	13.5	8	33.3	17.1	13.5	16.2	5	12	6	14.2
TKC-PD4-02G	4	G1/4	13.5	8	34.8	18.6	16	16.2	7	12	6	18.8
TKC-PD6-M5	6	M5	17	11.8	44.7	23.1	11.3	21.6	3.6	10	10	26
TKC-PD6-01G	6	G1/8	17	11.8	47.6	26	13.8	21.6	5	12	10	30.7
TKC-PD6-02G	6	G1/4	17	11.8	47.6	26	16	21.6	7	12	10	-
TKC-PD6-03G	6	G3/8	17	11.8	47.9	26.3	21.4	21.6	7	19	10	-
TKC-PD6-04G	8	G1/2	17	11.8	49.6	28	26.9	21.6	9	24	10	-
TKC-PD8-01G	8	G1/8	17.5	13.6	46.3	24	13.8	22.3	5	12	12	-
TKC-PD8-02G	8	G1/4	17.5	13.6	46.3	24	16	22.3	7	12	12	43.4
TKC-PD8-03G	8	G3/8	17.5	13.6	46.6	24.3	21.4	22.3	7	19	12	46.4
TKC-PD8-04G	8	G1/2	17.5	13.6	48.3	26	26.9	22.3	9	24	12	-
TKC-PD10-01G	10	G1/8	19.7	15.7	50	22.8	15.8	27.2	5	14	12.5	44.7
TKC-PD10-02G	10	G1/4	19.7	15.7	53.3	26.1	17.9	27.2	7	16	12.5	46.1
TKC-PD10-03G	10	G3/8	19.7	15.7	53.3	26.1	21.4	27.2	7	19	12.5	49.1
TKC-PD10-04G	10	G1/2	19.7	15.7	55	27.8	26.9	27.2	9	24	12.5	63.1
TKC-PD12-01G	12	G1/8	18.7	17.8	52.4	24.9	17.9	27.5	5	16	14	-
TKC-PD12-02G	12	G1/4	18.7	17.8	55.7	28.2	17.9	27.5	7	16	14	-
TKC-PD12-03G	12	G3/8	18.7	17.8	55.7	28.2	21.4	27.5	7	19	14	-
TKC-PD12-04G	12	G1/2	18.7	17.8	57.4	29.9	26.9	27.5	9	24	14	-

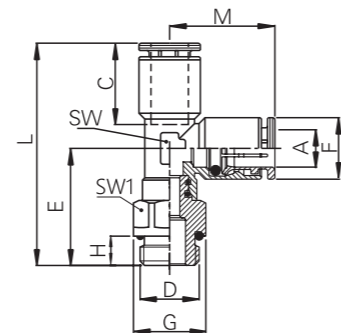

## TKC-PH-G...型快插管接头



尺寸表

型号	A	D	C	F	B	E	H	SW1	重量(g)
TKC-PH4-M5	4	M5	13.5	8	19	18	3.6	8	10.9
TKC-PH4-01G	4	G1/8	13.5	8	25	22.4	5	12	19
TKC-PH4-02G	4	G1/4	13.5	8	29	22.9	7	15	32.6
TKC-PH6-M5	6	M5	17	11.8	19	21	3.6	8	14.8
TKC-PH6-01G	6	G1/8	17	11.8	25	24.2	5	12	26.1
TKC-PH6-02G	6	G1/4	17	11.8	29	26.5	7	15	34.5
TKC-PH6-03G	6	G3/8	17	11.8	33	28.5	7	21	61.7
TKC-PH6-04G	6	G1/2	17	11.8	36	30.5	9	24	82.7
TKC-PH8-01G	8	G1/8	17.5	13.6	25	25.9	5	12	26.5
TKC-PH8-02G	8	G1/4	17.5	13.6	29	26.9	7	15	33.5
TKC-PH8-03G	8	G3/8	17.5	13.6	33	29.3	7.5	21	-
TKC-PH8-04G	8	G1/2	17.5	13.6	36	30.8	9	24	77.6
TKC-PH10-01G	10	G1/8	19.7	15.7	25	30.5	5	12	38.7
TKC-PH10-02G	10	G1/4	19.7	15.7	29	31.5	7	15	47
TKC-PH10-03G	10	G3/8	19.7	15.7	33	32.6	7	21	72.5
TKC-PH10-04G	10	G1/2	19.7	15.7	36	33.5	9	24	-
TKC-PH12-02G	12	G1/4	18.7	17.8	29	30	7	15	77.8
TKC-PH12-03G	12	G3/8	18.7	17.8	33	32.2	7	21	70
TKC-PH12-04G	12	G1/2	18.7	17.8	36	33.5	9	24	85.6
TKC-PH16-04G	16	G1/4	21.5	22.8	36	40.8	9	24	-

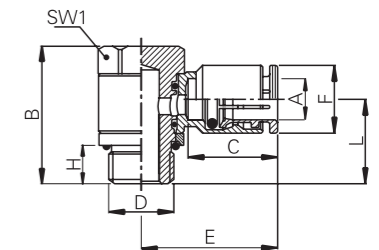

## TKC-PHF...型快插管接头

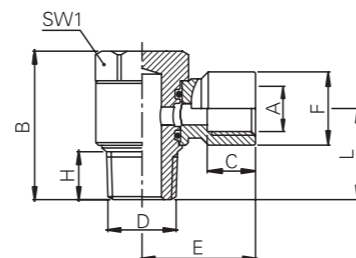

尺寸表

型号	A	D	C	F	L	E	H	B	SW1	重量(g)
TKC-PHF1/8-01	G1/8	R1/8	9	13.6	17.2	20	8	25	12	-
TKC-PHF1/4-02	G1/4	R1/4	10	16	19	24.5	9	29	15	-
TKC-PHF1/4-03	G1/8	R3/8	10	16	20.8	26	9.5	33	21	-
TKC-PHF3/8-03	G3/8	R3/8	10.5	20	23	29.3	9.5	33	21	-
TKC-PHF1/2-04	G1/2	R1/2	12.5	24	25.2	35.3	11.5	36	24	-

## TKC-PX...型快插管接头

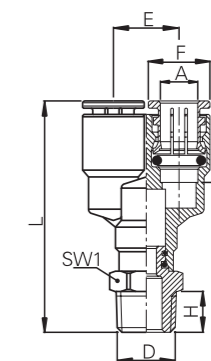

尺寸表

型号	A	D	C	F	L	E	H	SW1	重量(g)
TKC-PX4-01	4	R1/8	13.5	8	34.3	8.6	8	12	14.2
TKC-PX4-02	4	R1/4	13.5	8	34.3	8.6	9	14	-
TKC-PX6-01	6	R1/8	17	11.8	42.7	12.6	8	12	30
TKC-PX6-02	6	R1/4	17	11.8	43.2	12.6	9	14	40.1
TKC-PX6-03	6	R3/8	17	11.8	43.7	12.6	9.5	17	46.3
TKC-PX6-04	6	R1/2	17	11.8	45.7	12.6	11.5	21	58.7
TKC-PX8-01	8	R1/8	17.5	13.6	49.7	14.5	8	12	43.7
TKC-PX8-02	8	R1/4	17.5	13.6	50.2	14.5	9	14	47.8
TKC-PX8-03	8	R3/8	17.5	13.6	50.7	14.5	9.5	17	58.4
TKC-PX8-04	8	R1/2	17.5	13.6	52.7	14.5	11.5	21	-
TKC-PX10-01	10	R1/8	19.7	15.7	49.5	17	8	14	58.8
TKC-PX10-02	10	R1/4	19.7	15.7	50.5	17	9	14	58.7
TKC-PX10-03	10	R3/8	19.7	15.7	51	17	9.5	17	53.4
TKC-PX10-04	10	R1/2	19.7	15.7	53	17	11.5	21	72.9
TKC-PX12-01	12	R1/8	18.7	17.8	52.9	20	8	17	-
TKC-PX12-02	12	R1/4	18.7	17.8	53.9	20	9	17	80.4
TKC-PX12-03	12	R3/8	18.7	17.8	54.4	20	9.5	17	-
TKC-PX12-04	12	R1/2	18.7	17.8	56.4	20	11.5	21	-
TKC-PX14-04	14	R1/2	20.5	20.8	60	25	11.5	21	-
TKC-PX16-04	16	R1/2	22.8	22.8	62.5	25	11.5	21	-

## TKC-PHF-G...型快插管接头

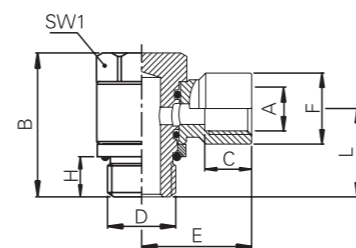

尺寸表

型号	A	D	C	F	L	E	H	B	SW1	重量(g)
TKC-PHF5-M5	M5	M5	5	10	10	12	3.6	22.5	8	-
TKC-PHF1/8-01G	G1/8	G1/8	9	13.6	17.2	20	5	25	12	-
TKC-PHF1/4-02G	G1/4	G1/4	10	16	19	24.5	7	29	15	-
TKC-PHF1/4-03G	G1/4	G3/8	10	16	20.8	26	7	33	21	-
TKC-PHF3/8-03G	G3/8	G3/8	10.5	20	23	29.3	7	33	21	-
TKC-PHF1/2-04G	G1/2	G1/2	12.5	24	25.2	35.3	9	36	24	-

## TKC-PX-G...型快插管接头

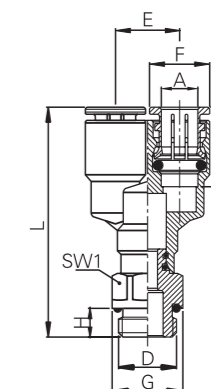

尺寸表

型号	A	D	C	F	L	E	G	H	SW1	重量(g)
TKC-PX4-M5	4	M5	13.5	8	32.4	8.6	8.9	3.6	8	12.6
TKC-PX4-01G	4	G1/8	13.5	8	34.3	8.6	13.5	5	12	-
TKC-PX4-02G	4	G1/4	13.5	8	34.3	8.6	16	7	12	-
TKC-PX6-M5	6	M5	17	11.8	40.7	12.6	11.3	3.6	10	27.8
TKC-PX6-01G	6	G1/8	17	11.8	42.7	12.6	13.8	5	12	37.5
TKC-PX6-02G	6	G1/4	17	11.8	43.2	12.6	16	7	12	-
TKC-PX6-03G	6	G3/8	17	11.8	43.2	12.6	21.4	7	19	-
TKC-PX6-04G	8	G1/2	17	11.8	45.7	12.6	26.9	9	24	-
TKC-PX8-01G	8	G1/8	17.5	13.6	49.7	14.5	13.8	5	12	-
TKC-PX8-02G	8	G1/4	17.5	13.6	49.7	14.5	16	7	12	46.1
TKC-PX8-03G	8	G3/8	17.5	13.6	50.7	14.5	21.4	7	19	-
TKC-PX8-04G	8	G1/2	17.5	13.6	52.7	14.5	26.9	9	24	-
TKC-PX10-01G	10	G1/8	19.7	15.7	49.5	17	15.8	5	14	-
TKC-PX10-02G	10	G1/4	19.7	15.7	49.5	17	17.9	7	16	-
TKC-PX10-03G	10	G3/8	19.7	15.7	51	17	21.4	7	19	66.7
TKC-PX10-04G	10	G1/2	19.7	15.7	53	17	26.9	9	24	-
TKC-PX12-01G	12	G1/8	18.7	17.8	52.9	20	17.9	5	16	-
TKC-PX12-02G	12	G1/4	18.7	17.8	52.9	20	17.9	7	16	-
TKC-PX12-03G	12	G3/8	18.7	17.8	54.4	20	21.4	7	19	-
TKC-PX12-04G	12	G1/2	18.7	17.8	56.4	20	26.9	9	24	-
TKC-PX14-04G	14	G1/2	20.5	20.8	60	25	26.9	9	24	-
TKC-PX16-04G	16	G1/2	21.5	22.8	62.5	25	26.9	9	24	-

## TKC-PZR...型快插管接头

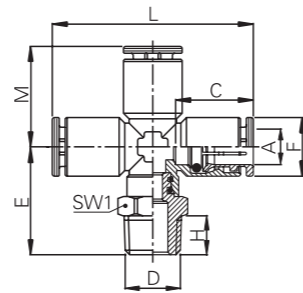

尺寸表										
型号	A	D	C	F	M	E	H	L	SW1	重量(g)
TKC-PZR4-01	4	R1/8	13.5	8	16.2	17.6	8	32.4	10	-
TKC-PZR4-02	4	R1/4	13.5	8	16.2	18.6	9	32.4	14	-
TKC-PZR6-01	6	R1/8	17	11.8	21.6	26	8	43.2	12	35
TKC-PZR6-02	6	R1/4	17	11.8	21.6	27	9	43.2	14	38.9
TKC-PZR8-01	8	R1/8	17.5	13.6	22.3	24	8	44.6	12	46.5
TKC-PZR8-02	8	R1/4	17.5	13.6	22.3	25	9	44.6	14	49.1
TKC-PZR8-03	8	R3/8	17.5	13.6	22.3	25.5	9.5	44.6	17	59.2
TKC-PZR8-04	8	R1/2	17.5	13.6	22.3	27.5	11.5	44.6	21	-
TKC-PZR10-03	10	R3/8	19.7	15.7	27.2	27.3	9.5	54.4	17	-
TKC-PZR12-04	12	R1/2	18.7	17.8	27.5	31.4	11.5	55	21	-

## TKC-PZR-G...型快插管接头

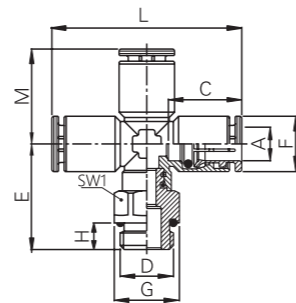

尺寸表											
型号	A	D	C	F	L	E	M	H	G	SW1	重量(g)
TKC-PZR4-M5	4	M5	13.5	8	32.4	18.6	16.2	3.6	8.9	8	
TKC-PZR4-01G	4	G1/8	13.5	8	32.4	17.1	16.2	5	13.5	12	
TKC-PZR4-02G	4	G1/4	13.5	8	32.4	18.6	16.2	7	16	12	
TKC-PZR6-M5	6	M5	17	11.8	43.2	23.1	21.6	3.6	11.3	10	
TKC-PZR6-01G	6	G1/8	17	11.8	43.2	26	21.6	5	13.8	12	
TKC-PZR6-02G	6	G1/4	17	11.8	43.2	26	21.6	7	16	12	
TKC-PZR6-03G	6	G3/8	17	11.8	43.2	26.3	21.6	7	21.4	19	
TKC-PZR6-04G	8	G1/2	17	11.8	43.2	28	21.6	9	26.9	24	
TKC-PZR8-01G	8	G1/8	17.5	13.6	44.6	24	22.3	5	13.8	12	
TKC-PZR8-02G	8	G1/4	17.5	13.6	44.6	24	22.3	7	16	12	
TKC-PZR8-03G	8	G3/8	17.5	13.6	44.6	24.3	22.3	7	21.4	19	
TKC-PZR8-04G	8	G1/2	17.5	13.6	44.6	26	22.3	9	26.9	24	
TKC-PZR10-01G	10	G1/8	19.7	15.7	54.4	22.8	27.2	5	15.8	14	
TKC-PZR10-02G	10	G1/4	19.7	15.7	54.4	26.1	27.2	7	17.9	16	
TKC-PZR10-03G	10	G3/8	19.7	15.7	54.4	26.1	27.2	7	21.4	19	
TKC-PZR10-04G	10	G1/2	19.7	15.7	54.4	27.8	27.2	9	26.9	24	
TKC-PZR12-01G	12	G1/8	18.7	17.8	55	24.9	27.5	5	17.9	16	
TKC-PZR12-02G	12	G1/4	18.7	17.8	55	28.2	27.5	7	17.9	16	
TKC-PZR12-03G	12	G3/8	18.7	17.8	55	28.2	27.5	7	21.4	19	
TKC-PZR12-04G	12	G1/2	18.7	17.8	55	29.9	27.5	9	26.9	24	

## TKC-PG...型快插管接头

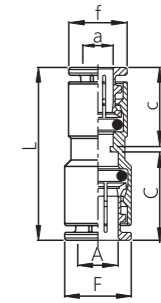

尺寸表								
型号	A	F	C	L	a	f	c	重量 (g)
TKC-PG6-4	6	11.8	17	30.8	4	8	13.5	12.5
TKC-PG8-4	8	13.6	17.5	32.2	4	8	13.5	13.6
TKC-PG8-6	8	13.6	17.5	34.8	6	11.8	17	18.4
TKC-PG10-6	10	15.7	19.7	37.1	6	11.8	17	22.7
TKC-PG10-8	10	15.7	19.7	38.4	8	13.6	17.5	22.8
TKC-PG12-8	12	17.8	18.7	37.8	8	13.6	17.5	27.4
TKC-PG12-10	12	17.8	18.7	40.1	10	15.7	19.7	29
TKC-PG16-12	16	22.8	21.5	41.8	12	17.8	18.7	45.5
TKC-PG16-14	16	22.8	21.5	44.7	14	20.8	20.5	59.5

## TKC-PU...型快插管接头

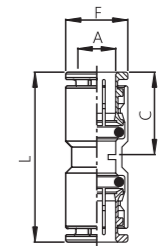

尺寸表					
型号	A	F	C	L	重量 (g)
TKC-PU4	4	8	13.5	28.7	5.3
TKC-PU6	6	11.8	17	33.6	15.4
TKC-PU8	8	13.6	17.5	36.1	20
TKC-PU10	10	15.7	19.7	41	26.5
TKC-PU12	12	17.8	18.7	39	32.1
TKC-PU14	14	20.8	20.8	44.4	51.7
TKC-PU16	16	22.8	21.5	45	62.9

## TKC-PM...型快插管接头

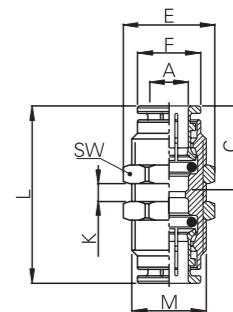

尺寸表									
型号	A	F	L	C	M	E	SW	K	重量 (g)
TKC-PM4	4	8	28.7	13.5	M10×1	15.8	14	9	12
TKC-PM6	6	11.8	35.4	17	M14×1	19.1	17	14	28.4
TKC-PM8	8	13.6	36.1	17.5	M16×1	21.4	19	15	37.7
TKC-PM10	10	15.7	40.6	19.7	M18×1	24.9	22	15	48.5
TKC-PM12	12	17.8	39	18.7	M20×1	26.9	24	15	56.6
TKC-PM14	14	20.8	44.4	20.8	M23×1	30.4	27	14	86.4
TKC-PM16	16	22.8	45	21.5	M26×1	33.8	30	18	105.5

## TKC-PE...型快插管接头

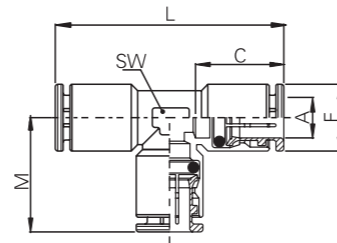

尺寸表

型号	A	F	C	L	M	SW	重量 (g)
TKC-PE4	4	8	13.5	32.4	16.2	6	7.9
TKC-PE6	6	11.8	17	43.2	21.6	10	28.8
TKC-PE8	8	13.6	17.5	44.6	22.3	12	33.9
TKC-PE10	10	15.7	19.7	54.4	27.2	12.5	46.1
TKC-PE12	12	17.8	18.7	55	27.5	14	52.1
TKC-PE14	14	20.8	20.5	60.4	30.2	19	121
TKC-PE16	16	22.8	21.5	66	33	19	111.1

## TKC-PV...型快插管接头

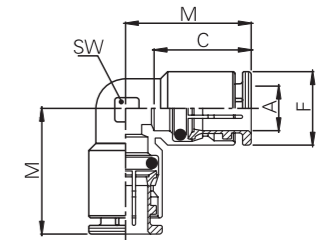

尺寸表

型号	A	F	M	C	SW	重量 (g)
TKC-PV4	4	8	16.2	13.5	6	5.8
TKC-PV6	6	11.8	21.6	17	10	18.8
TKC-PV8	8	13.6	22.3	17.5	12	24
TKC-PV10	10	15.7	27.2	19.7	12.5	29.5
TKC-PV12	12	17.8	27.5	18.7	14	40.9
TKC-PV14	14	20.8	30.2	20.8	19	89.6
TKC-PV16	16	22.8	33	21.5	19	83.3

## TKC-PEG...型快插管接头

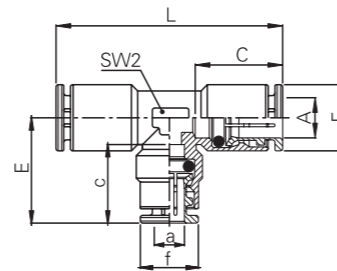

尺寸表

型号	A	F	C	a	f	c	E	L	SW2	重量 (g)
TKC-PEG6-4	6	11.8	17	4	8	13.5	17.5	43.2	10	22.4
TKC-PEG8-6	8	13.6	17.5	6	11.8	17	21.7	45	12	34.5
TKC-PEG10-6	10	15.7	19.7	6	11.8	17	25	55	12.5	46
TKC-PEG10-8	10	15.7	19.7	8	13.6	17.5	24.5	55	12.5	47.7
TKC-PEG12-8	12	17.8	18.7	8	13.6	17.5	26.3	55.6	14	59.4
TKC-PEG12-10	12	17.8	18.7	10	15.7	19.7	26.8	55.6	14	64.9
TKC-PEG16-12	16	22.8	21.5	12	17.8	18.7	30	66	19	108.1
TKC-PEG16-14	16	22.8	21.5	14	20.8	20.5	30.5	66	19	117.8

## TKC-PY...型快插管接头

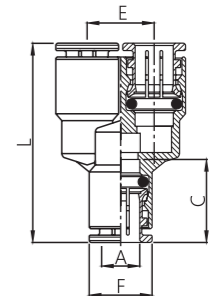

尺寸表

型号	A	F	L	C	E	重量 (g)
TKC-PY4	4	8	30.7	13.5	8.6	9.2
TKC-PY6	6	11.8	37.9	17	12.6	28.2
TKC-PY8	8	13.6	42.2	17.5	14.5	38.5
TKC-PY10	10	15.7	45.8	19.7	17	60.2
TKC-PY12	12	17.8	47.4	18.7	20	68
TKC-PY14	14	20.8	50.8	20.8	25	116.3
TKC-PY16	16	22.8	52.4	21.5	25	101.7

## TKC-PZA...型快插管接头

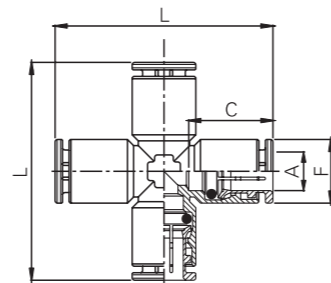

尺寸表

型号	A	F	C	L	重量 (g)
TKC-PZA4	4	8	13.5	32.4	11
TKC-PZA6	6	11.8	17	43.2	33.9
TKC-PZA8	8	13.6	17.5	44.6	338.5
TKC-PZA10	10	15.7	19.7	54.4	59.8
TKC-PZA12	12	17.8	18.7	55	78.8

## TKC-PW...型快插管接头

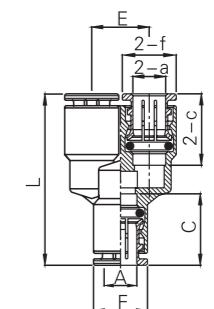

尺寸表

型号	A	F	C	L	E	2-a	2-f	2-c	重量 (g)
TKC-PW6-4	6	11.8	17	34.8	12.6	4	8	13.5	28.5
TKC-PW8-6	8	13.6	17.5	39.7	14.5	6	11.8	17	43.3
TKC-PW10-6	10	15.7	19.7	41.7	17	6	11.8	17	-
TKC-PW10-8	10	15.7	19.7	43.8	17	8	13.6	17.5	61.2
TKC-PW12-8	12	17.8	18.7	45	20	8	13.6	17.5	82.7
TKC-PW12-10	12	17.8	18.7	46.7	20	10	15.7	19.7	76.7

## TKC-MPOC...微型快插管接头

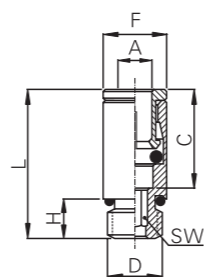

尺寸表

型号	A	F	C	D	L	H	SW	重量(g)
TKC-MPOC3-M3	3	5.8	9	M3	13.6	3	2	
TKC-MPOC3.17-M3	3.17	5.8	9	M3	13.6	3	2	
TKC-MPOC3-M5	3	5.8	9	M5	13.6	3.6	2	
TKC-MPOC3.17-M5	3.17	5.8	9	M5	13.6	3.6	2	

## TKC-MPL...微型快插管接头

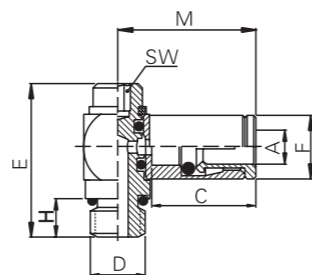

尺寸表

型号	A	F	C	D	M	E	H	SW	重量(g)
TKC-MPL3-M3	3	5.8	9	M3	12.7	13.5	3	2	
TKC-MPL3.17-M3	3.17	5.8	9	M3	12.7	13.5	3	2	
TKC-MPL3-M5	3	5.8	9	M5	12.7	14	3.6	2	
TKC-MPL3.17-M5	3.17	5.8	9	M5	12.7	14	3.6	2	

## TKC-MPU...微型快插管接头

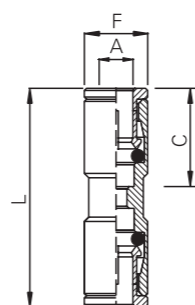

尺寸表

型号	A	F	C	L	重量(g)
TKC-MPU3	3	5.8	9	9	
TKC-MPU3.17	3.17	5.8	9	9	